



Streamtek Corp. brings you solutions for a new economy.

Tool Cooler

Technical Guide

Tool Coolers use filtered compressed air (80-100 PSIG) and a vortex tube to produce cold air for industrial spot cooling. Cold air machining eliminates mist coolants and heat-related parts growth while improving tool life, part tolerance and surface finish quality.

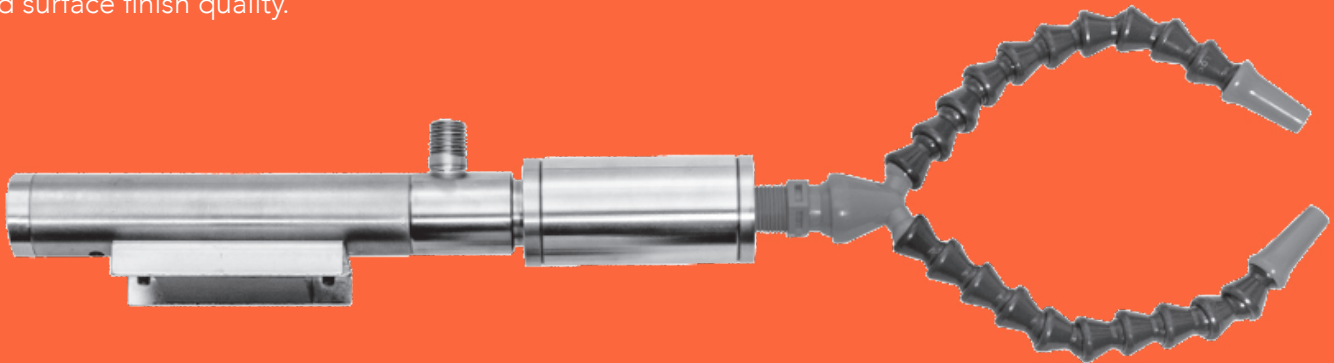

Version 1.0



CONTACT

ADDRESS

Streamtek Corp. – Canada,
6-295 Queen Street
East Suite 384
Brampton ON.,
L6W 4S6

PHONE & FAX

US & Canada phone : 1-888-218-6548
Worldwide phone: 1-705-770-4455

US & Canada phone : 1-888-218-6548
Worldwide phone: 1-705-770-4455

ONLINE

Sales Email: sales@stream-tek.com
Tech Help Email: support@stream-tek.com

Website: www.stream-tek.com

1 Cold Air Gun Specifications

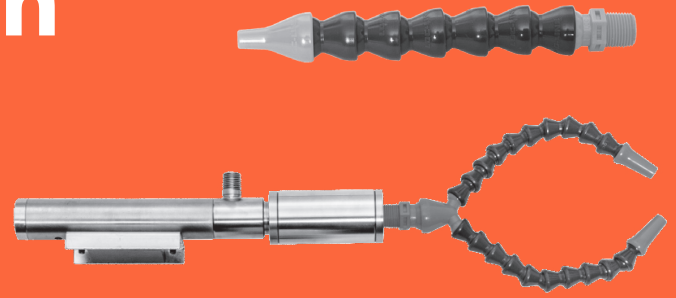

Use and Selection of your Tool Cooler:

The Single Point Tool Coolers should be used where a concentrated airflow is needed such as in grinding & drilling. The Dual Point versions are typically used in applications where the heat is generated over a large surface area such as in milling, sawing, chill rolls or application of hot melt adhesives.

Controlling the Cold Air:

The Streamtek Tool Cooler Cold Gun System provides instant cold air! A solenoid valve (Model SLD00-1) is an excellent way to turn the compressed air supply to the Cold Gun system on-off as it is needed, which in turn conserves compressed air usage. A Manual Shutoff Valve (Model VLV014-1) can also be used to cycle on and off.

The Compressed Air Supply:

The Tool Cooler Cold Gun System is engineered to use compressed air supply of 80-100 PSIG (5.5 to 6.9 BAR). If lower input pressures are given, both temperature drop and flow will be reduced. A clean dry source of compressed air is imperative in the operation of the Streamtek Vortex Tube Tool Cooler.

Tool Cooler Specifications					
Model No.	Pressure Supply		Air Consumption		PSIG
	PSIG	BAR	SCFM	SLPM	dBA
Regular Tool Coolers TC015S, T015D	100	6.9	15	425	72
Advanced Tool Cooler TC030S, TC030D	100	6.9	30	850	83

2 Cold Air Gun

Dimensions

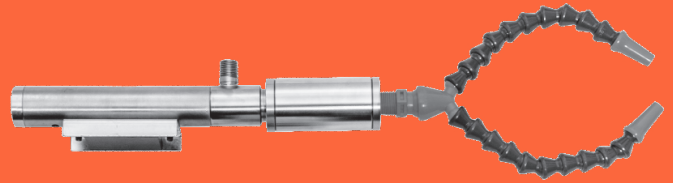

No Coolant or liquids, ozone-depleting chemicals or residue.

Maintenance-free no moving parts.

The magnetic base provides user-friendly mounting and portability.

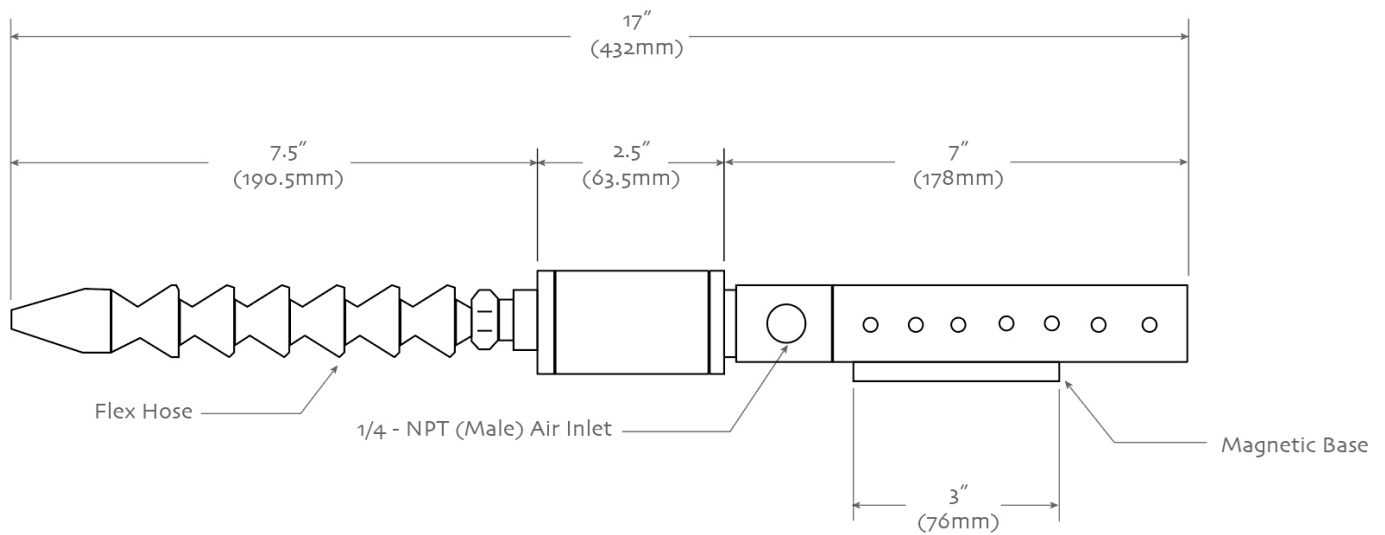

2 Cold Air Gun

Installation & Maintenance

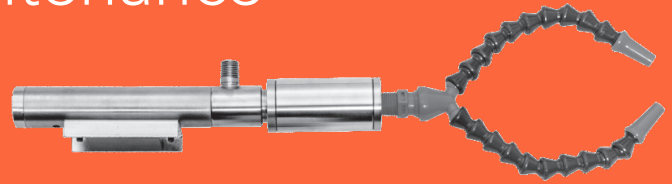

01 Recommended Hose Runs

** Do not use restrictive fittings such as quick couplings/connects. They can "starve" your Tool Cooler by causing excessive line pressure drop.

LENGHT OF RUN	SIZE OF PIPE/HOSE
1 - 25ft	Use 1/4" pipe or 3/8" air hose
26 - 50ft	Use 3/8" pipe or 1/2" air hose
51ft and above	Use 1/2" pipe or larger

02 Compressed Air Supply

ALWAYS USE a minimum 5 micron filter with a float type auto drain. All Streamtek™ auto drain air filters are float actuated to eliminate the possibility of water flow into the enclosure, even during continuous operation. To prevent problems associated with oil, use a properly sized oil removal filter with at least a .3 micron rating. This should be installed downstream from automatic drain filter separator. Install ALL filters within 10 to 15 feet (3 to 4.6m) of the cooling unit. NOTE: All Streamtek Tool Coolers are designed to use normal shop air supplies of 80 to 100 PSIG (5.5 to 6.9 BAR).

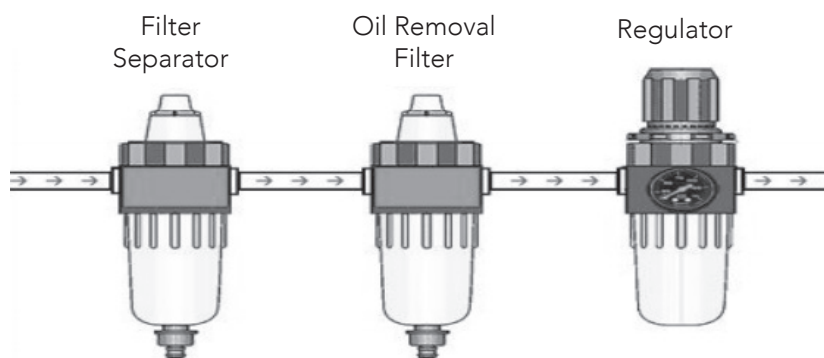

RECOMMENDED FILTER SYSTEM

03 Using the Streamtek Tool Cooler

1. Install the Tool Cooler using the supplied magnetic mounting base.
2. Direct the cold air to the spot that needs to be cooled using the flexible hose kit.
3. You can reduce the temperature by using a pressure regulator. If maximum cooling is not required, a lower air flow will reduce overall air use.

04 Troubleshooting & Maintenance

To set your Vortex Tube to the desired temperature simply insert a thermometer at the cold end and adjust the slotted valve at the hot air exhaust. Closing this valve will increase cold air flow at cold end, but with less cold air. Opening the valve will decrease cold air flow at cold end, but produce more cold air.

The optimum cooling will be reached when the difference from the cold air and compressed air temperature drop is 28°C (50°F); if the inlet air is say 45°C (80°F).

05 Troubleshooting & Maintenance

If your Vortex Tube is not performing up to par, check for these common problems:

1. **No Cold Flow** – If you set your Vortex Tube to more than 28°C (50°F) drop from compressed air supply temperature, the cold end could freeze up; therefore blocking the cold end exhaust. See the following:
 - (a) Turn off Vortex Tube for 5 to 10 minutes; it will thaw.
 - (b) Turn off Vortex Tube and blow compressed air into the cold end.
 - (c) Use dry air with an atmospheric dew point of -40° or less.
2. **Back Pressure** – Back pressure over 2 PSIG (0.1 BAR) will reduce the performance of the Vortex Tube. A 5 PSIG (0.3 BAR) will affect performance by approximately 2.8°C (5°F). If ducting is used on the cold air exhaust, ensure that the total cross-sectional area is equal to or greater than the area of the cold end exhaust on the Vortex Tube.
3. **Inlet Temperature** – The Vortex Tube will only drop the temperature based on the temperature from supply compressed air. Often times the compressed air supply temperature will be warmer than usual due to compressed air lines running near furnaces, across ceilings, direct sunlight, etc.
4. **Inlet Pressure** – Inlets pressures below 80 to 100 PSIG will cause poor performance. Restrictions in the compressed air supply lines will negatively affect performance and cause excessive pressure drops. Be sure to measure the PSIG (BAR) at the inlet of the Vortex Tube while operating.
5. **Cold Cap/Muffler Loose** – The cold muffler and cap will cause poor performance if loose. Ensure tight!!